

INNOFIL B-31

NET DIGITAL BAGGING SCALE



The Innofil B-31 is designed for bagging products with irregular shapes that don't flow well, when high accuracy is needed.

PACKWEIGH
INNOVATIVE PACKAGING SOLUTIONS

Features

- Internal belt over deck product conveyor
- Two speed, main feed & dribble feed
- Rinstrum panel mount batch controller
- LCD display with LED back lighting
- 24VDC controls
- RS232 port for data transfer to computer
- Supports optical communication with PC
- Product levelling gate for increased accuracy
- Product catch gate
- High quality load cells
- Weigh bin with pneumatic bomb doors
- Transition Shute
- Service platform
- Ladder & hand rails

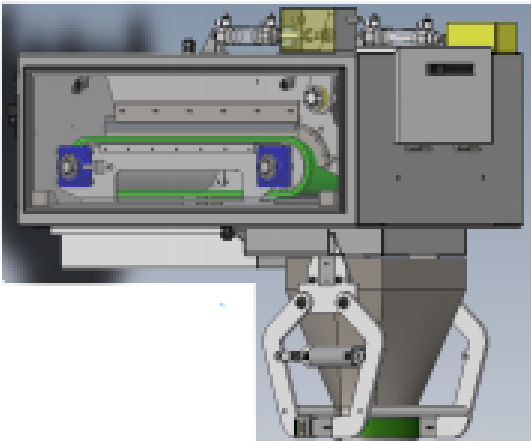

About Packweigh

Packweigh Equipment design & manufacture as well as import equipment from all over the world, and with a modern workshop and engineering department, can furnish an innovative solution to supply you with equipment to suit your specific needs.

Packweigh Equipment also carries an extensive range of spare parts and has the expertise and staff to service your machinery for smooth and trouble free operation.

Packweigh Equipment

www.packweigh.com.au | sales@packweigh.com.au

Ph 07 38231033 | 14 Veronica St Capalaba, QLD, 4157